

# BASIC RULES OF PACKAGING

What does the package have to endure during the transportation?

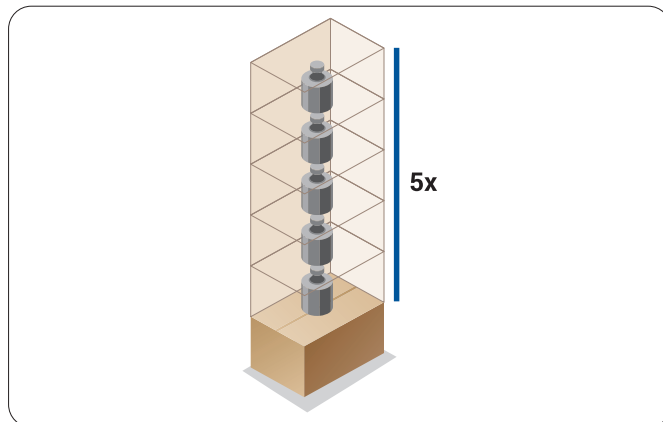

**The test of the firmness of the package:**  
the package with the product must endure 5x of its weight

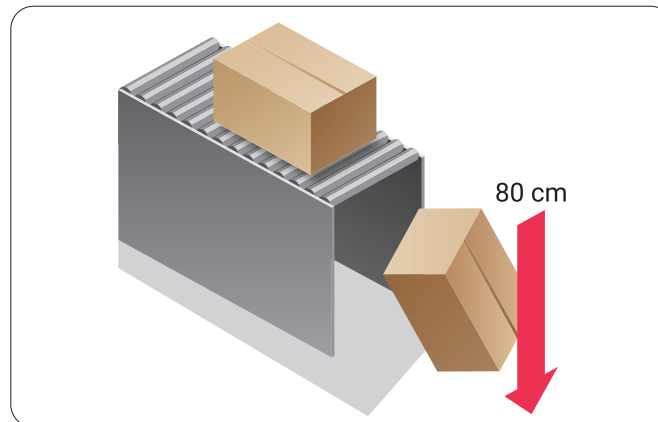

**The falling crash test:** free fall from 60-80 cm for weight 0-30 kg (ČSN EN 22248 and ČSN EN ISO 24180-20)

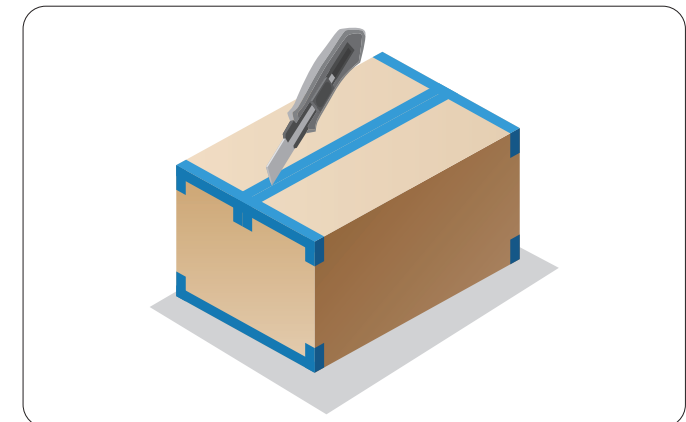

**Original packaging security:** using the company costumed tapes

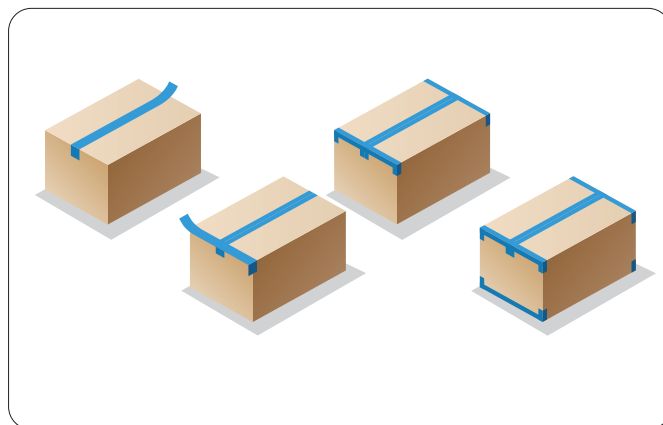

**The right taping of the consignment:**  
the shape of double "H"

**PRINCIPLES:**

- use only good quality packaging materials
- protect the surface and sensitive parts of the product
- separate and interpolate each product
- eliminate shifting and moving of the product
- create deformation zones on all sides
- fill the boxes with filling materials up to the top
- the whole package must be firm and compact
- if needed use the manipulation signs

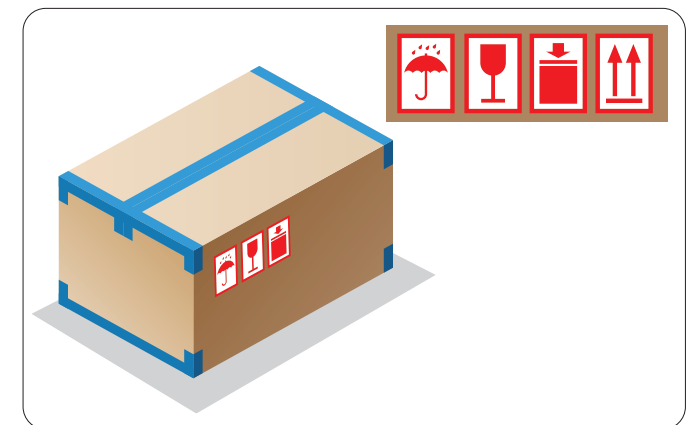

**Manipulation signs:** do not substitute good quality packaging and filling (ČSN EN ISO 780). The consignment is labeled with just one PPL Label!

# SUITABLE TRANSPORT COVERS

Security of the content, crash protection, firmness and compactness, deformation zones

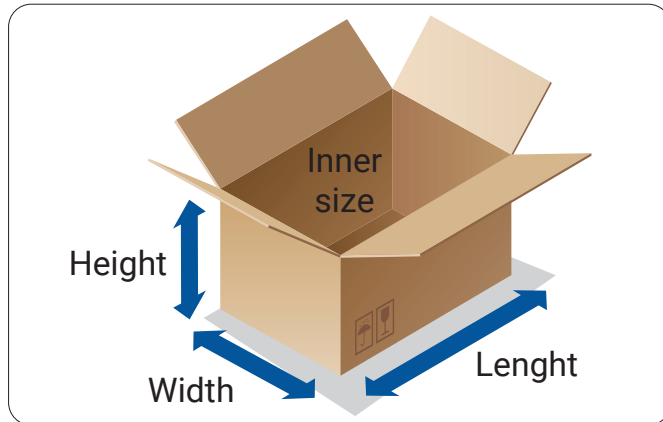

**Boxes of corrugated board:**  
quality - firmness - stability - compactness



**Post boxes of corrugated board**

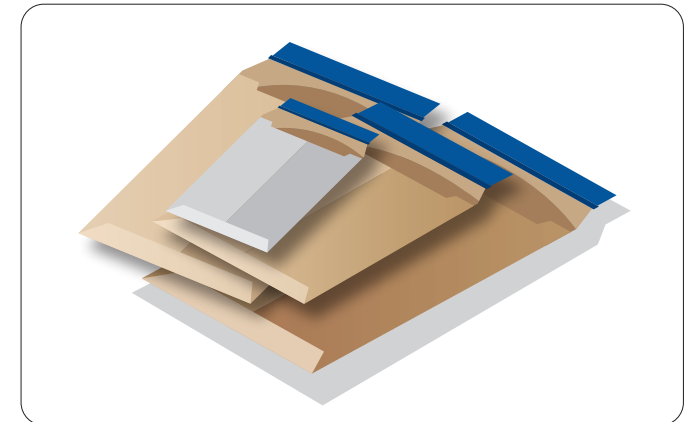

**Security envelopes**

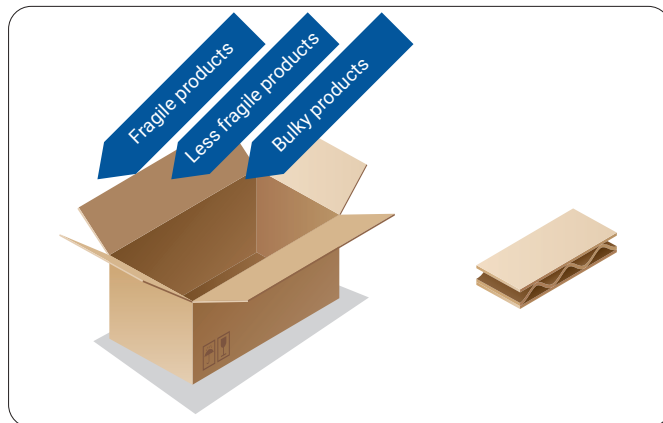

**Threewall cardboard**  
(of various level quality)

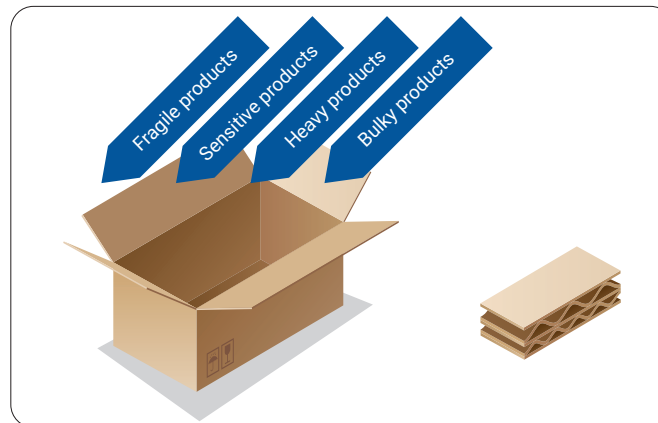

**Fivewall cardboard**  
(of various level quality)

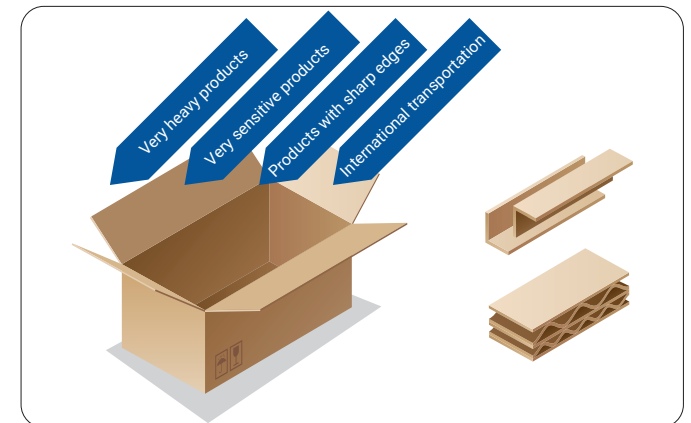

**Using of special L-shaped or U-shaped tendons in corners and sides**

# PRODUCT FEATURES AND TRANSPORT RESTRICTION

Division according to sensitivity and features



**Fragile products:** glass, porcelain, ceramics, etc.

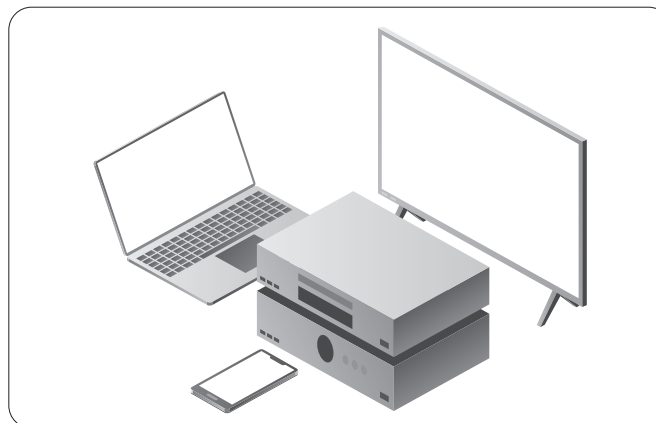

**Sensitive products:** mechanical and optical gadgets, electronics, etc.

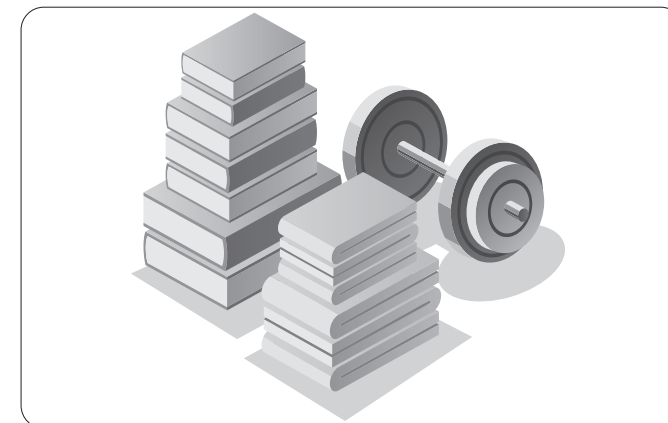

**Robust products:** books, metal parts, textile, etc.



**Maximal weight of the consignment is 31,5 kg:**  
consignment must be manipulated by 1 person only

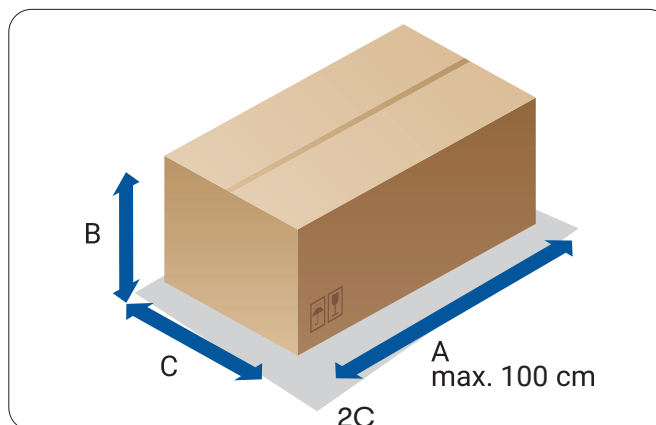

**Maximal size of the consignment: Length:** 100 x 60 x 60 cm  
**Size:**  $A + 2B + 2C = \text{max. } 300 \text{ cm}$



**The consignment must not contain explosives, weapons, flammable, or chemical substances.**  
(see the transport conditions of PPL)

# TRANSPORT CONDITIONS AND RISK

Manipulation with the consignment: 6-8x loading, unloading and transportation using the conveyor belt

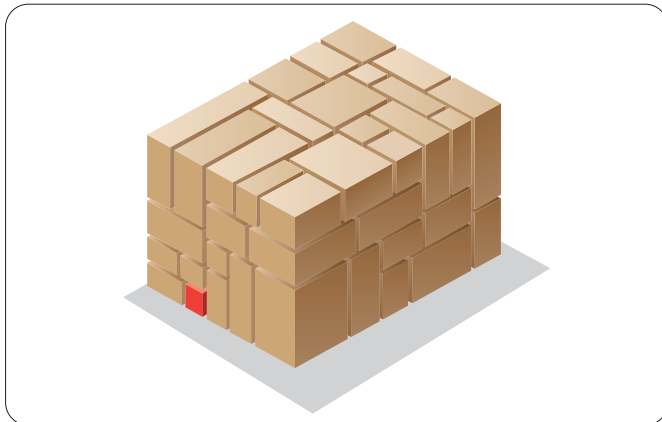

**Pressure:** your consignment can be up to 2,5 m under the pile

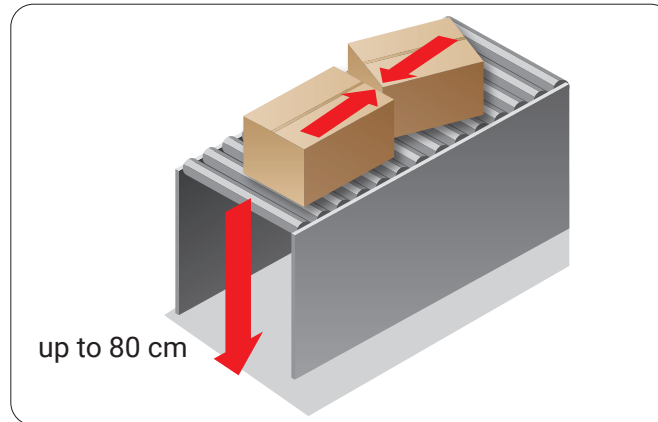

**Crashes and falls:** during the manipulation on the conveyor belt, up to 80 cm

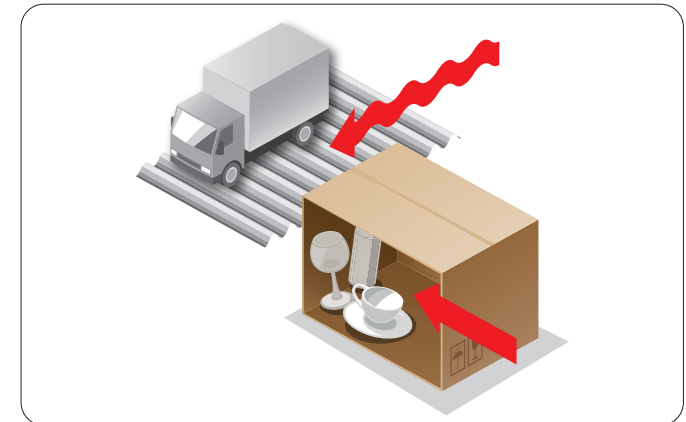

**Vibration:** the content of the consignment can be moved to the side within the package

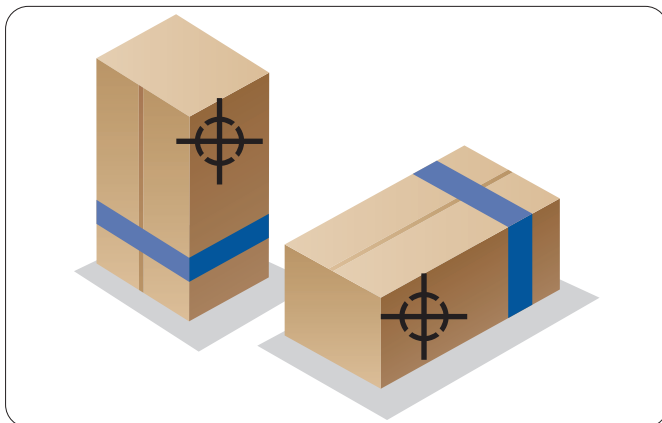

**The centroid:** your consignment will be transported in the most stable position



**It is not possible to tie, tape, join by stretch foil or stick the consignments. Consignments attached to each other do not enable manipulation and can be torn.**



**The consignment must be labeled with one PPL label.**

# INNER FILLING AND FIXATION

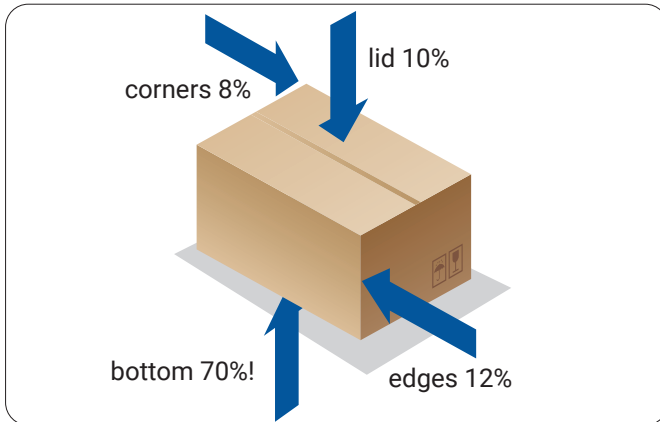

**The risk of falling of the transported consignment in percentage**



**Product with no inner filling:**  
the risk of damage is very high!

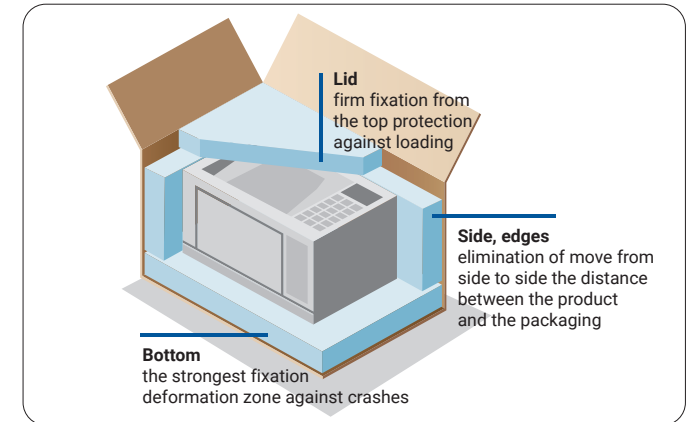

**Form deformation zones:**  
use fixing and filling materials

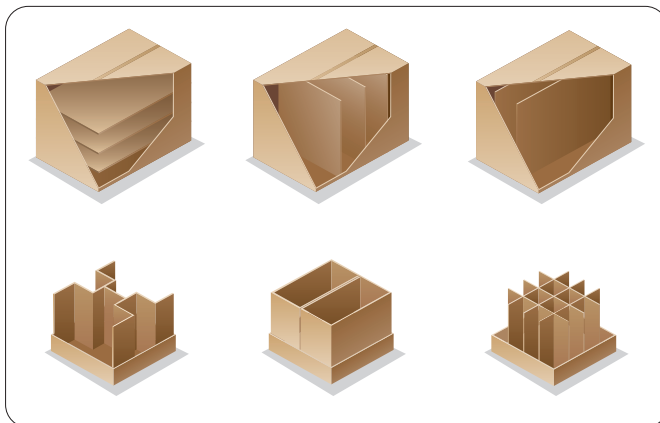

**Separation of the products:**  
elimination of damage (grids, curves, and packaging)

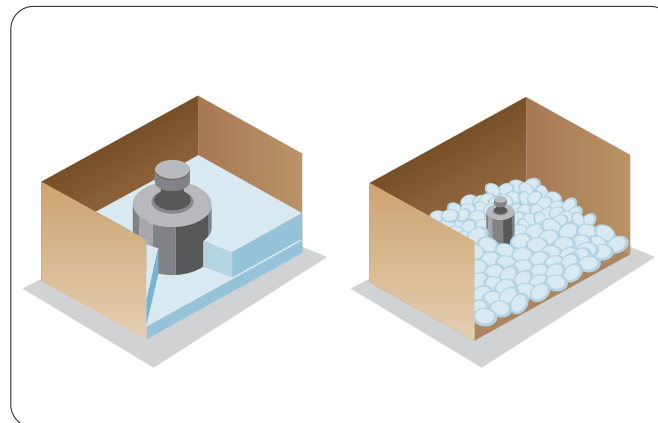

**Light products:** soft and airy fixation  
**Heavy products:** rigid and firm fixation

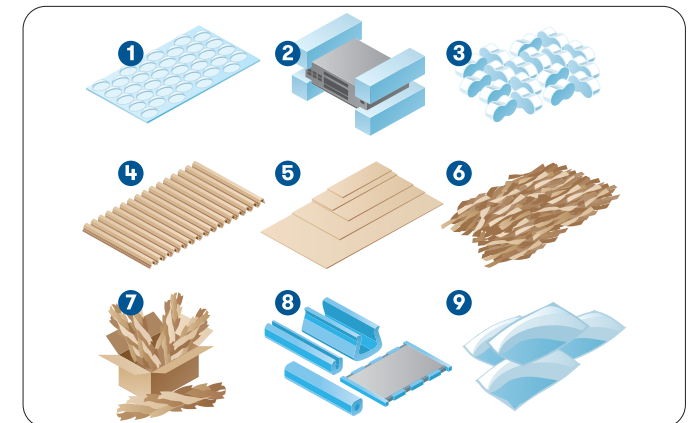

**Various kinds of fixation:** 1. bubble foil 2. polystyrene fixation 3. flopak pieces 4. cardboard 5. cardboard curves 6. kartofix 7. padpak 8. foam profiles 9. cello airy bags